

OPERATING MANUAL

MIXING CONSOLE

CMX-842/1242/1642

interM

Introduction

Thank you for purchasing a CMX-2 Bus SERIES Mixing Console. The CMX-2 Bus Series provides an excellent balance of operability, functionality and ease of use. In order to take full advantage of the CMX-2 Bus Series capabilities and enjoy years of trouble-free use, please read this manual carefully.

Unpacking and Installation

Although it is neither complicated to install nor difficult to operate your set, a few minutes of your time is required to read this manual for a properly wired installation and becoming familiar with its many features and how to use them.

Please take a great care in unpacking your set and do not discard the carton and other packing materials. They may be needed when moving your set and are required if it ever becomes necessary to return your set for service. Never place the unit near radiators, in front of heating vents, to direct sun light, in excessive humid or dusty location to avoid early damage and for your years of quality entertainment. Connect your complementary components as illustrated in the following page.

Features

- The CMX-842 provides 8 channels of input (the CMX-1242 has 12 channels, the CMX-1642 has 16 channels) that can be mixed down to a stereo signal.
- 4 AUX SEND, 2 STEREO AUX RETURN
4 AUX SEND systems and 2 STEREO AUX RETURN are provided. Even when two 1-In/2-Out effect devices are connected, two more AUX SEND systems are still available for use.
- XLR type connectors are provided for the MIC jacks and phone connectors are provided for the LINE jacks.
- The MONO OUT output provides a convenient connection for a sub amp for monitoring, or for checking phase cancellation.
- The PFL (Pre Fader Listen) function allows you to monitor any input channel before the channel fader.
- The AFL (After Fader Listen) function allows you to monitor the output signal from MONO OUT or AUX SEND through headphones at any time.
- Each input channel has a INPUT CH INSERT I/O jack, allowing you to connect effect devices independently for each channel.
- The TAPE IN and REC OUT jacks provide convenient connections for tape deck playback and recording.
- Phantom power is provided for easy connection of condenser microphones requiring an external power supply.
- All inputs include 3-band EQ and MID frequency is variable.

Contents

• Precautions	3
• Control Panel	
Channel Control Section	4
Master Control Section	6
• Connectors	9
• Application Example	11
• Specification	
General Specification	12
Input/Output Specification	13
• Block and Level Diagram	14
• Schematic Diagram	15

Precautions

1. AVOID EXCESSIVE HEAT, HUMIDITY, DUST AND VIBRATION

Keep the unit away from locations where it is likely to be exposed to high temperatures or humidity—such as near radiators, stoves, etc. Also avoid locations which are subject to excessive dust accumulation or vibration which could cause mechanical damage.

2. VENTILATION

The unit has ventilation slots on the side and bottom panels. Do not block these vents.

3. AVOID PHYSICAL SHOCKS

Strong physical shocks to the unit can cause damage. Handle it with care.

4. DO NOT OPEN THE CASE OR ATTEMPT REPAIRS OR MODIFICATIONS YOURSELF

This product contains no user-serviceable parts. Refer all maintenance to qualified INTER-M service personnel. Opening the case and/or tampering with the internal circuitry voids the warranty.

5. ALWAYS POWER OFF BEFORE MAKING CONNECTIONS

Always turn the power OFF before connecting or disconnecting cables. This is important to prevent damage to the unit itself as well as other connected equipment.

6. HANDLE CABLES CAREFULLY

Always plug and unplug cables—including the AC power cord—by gripping the connector, not the cord.

7. CLEAN WITH A SOFT DRY CLOTH

Never use solvents such as benzine or thinner to clean the unit. Wipe clean with a soft, dry cloth.

Control Panel

■ CHANNEL CONTROL SECTION

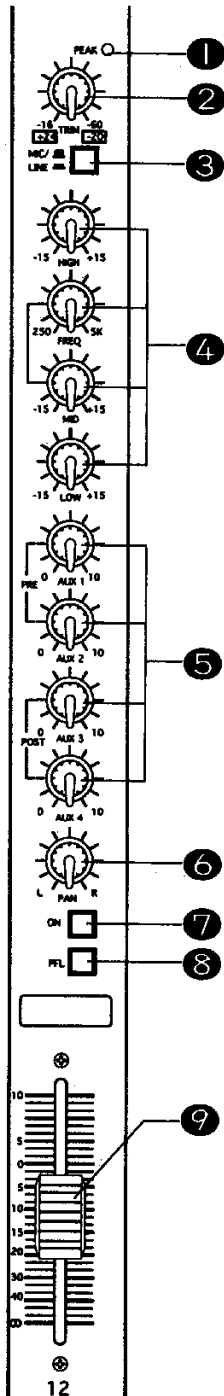

1. PEAK INDICATOR

This indicator detects peak level after the EQ. It will light red at 3dB before clipping to warn that clipping level has nearly been reached.

2. TRIM CONTROL

According to the level of the input signal, use this knob to adjust the input to an appropriate level.

The best balance of S/N and dynamic range will be achieved if you adjust the TRIM control so that the ① peak indicator lights occasionally.

3. INPUT SELECTOR

This switch selects the input connector for the channel. When MIC (☐) is selected, the input signal will be taken MIC connector (Balanced XLR type).

When LINE (☐) is selected, the input signal will be taken LINE connector (Balanced phone jack).

4. EQ CONTROLS (HIGH, MID FREQ, MID, LOW)

This is a 3-band equalizer with center frequencies, range, and type as shown below.

HIGH: 12KHz, ± 15 dB shelving type

MID: 250Hz~5KHz (variable) ± 15 dB peaking type

LOW: 80Hz, ± 15 dB shelving type

The frequency response is flat when the knob is in the center position.

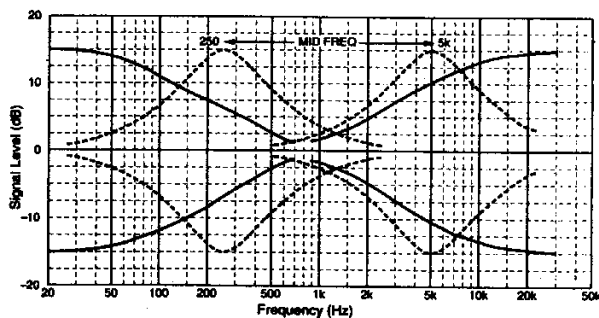

5. AUX 1~4 CONTROLS

This knobs control the level of the signals sent to AUX buses.

- The AUX1 and AUX2 controls are pre-fader, and the signal levels sent to the AUX1 and 2 buses will be unaffected by the channel fader setting.

- The AUX3 and AUX4 controls are post-fader, and the signal level sent to the AUX3 and 4 buses will be affected by the channel fader setting.

6. PAN CONTROL

This knob assigns the signal of each channel to the STEREO L, R bus, determining the stereo position of the sound.

7. CHANNEL ON SWITCH

When this switch is on, the signal of each channel will be sent to the STEREO L, R bus and the AUX 1-4 buses.

When this switch is off, the output signal to each bus will be muted completely. This switch should be turned off for unused channels.

8. CHANNEL PFL SWITCH

This switch allows you to monitor the pre-fader channel input signal through headphones. It is convenient to use PFL when you wish to check the sound of the input signal, or when troubleshooting a specific channel.

9. CHANNEL FADER

This fader controls the output level of the input channel signal, determining the volume balance between channels. The channel fader should be lowered for unused channels.

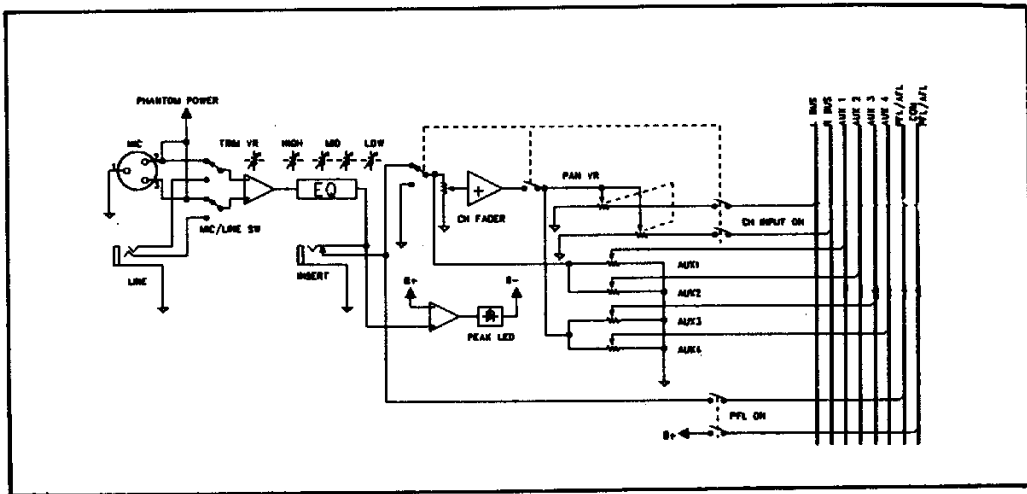

■ MASTER CONTROL SECTION

1. AUX RETURN 1, 2 CONTROLS

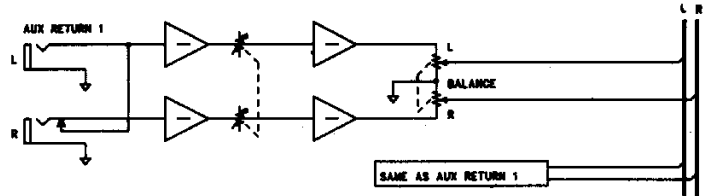

(BALANCE)

The BALANCE knob adjusts the balance of the AUX RETURN signal.

For example if this knob is turned all the way to the left, the signal will be sent only to the L bus.

If it is turned all the way to the right, the signal will be sent only to the R bus.

If the knob is set to the center position, the same amount of signal will be sent to the stereo L and R buses.

(LEVEL)

The level knobs control the level at which signals from effect unit etc. Connected to the L/MONO, R jacks of AUX RETURN 1, 2 are sent to the L, R bus.

If a plug is inserted into only the L/MONO jack, the same signal will be sent to both L and R buses.

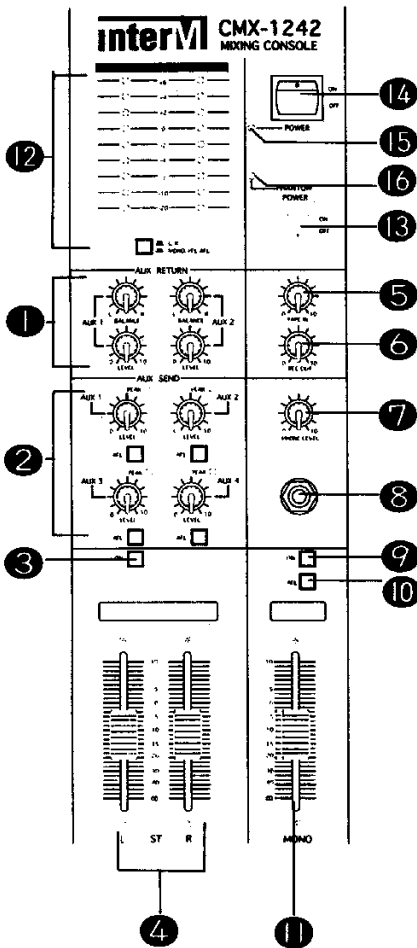

2. AUX SEND CONTROL, SWITCH AND PEAK INDICATOR

(LEVEL)

This adjusts the signal level of the AUX SEND output. A position at the nominal (-) marking is the nominal level.

(AFL SWITCH)

This monitors the AUX SEND signal. This is on when the switch is pressed in.

(PEAK INDICATOR)

This indicator lights when the level of the output signal reaches 3dB before clipping.

3. STEREO ON SWITCH

This switch turns the ST OUT output on/off.

4. STEREO L, R MASTER FADER

These faders adjust the final level of the combined signals from all channels, and send them from the STEREO OUT connectors.

When the meter selector switch is not pressed (■), you to monitor the L and R outputs by the meter.

5. TAPE IN CONTROL

This knob adjusts volume of a tape deck etc. connected to the TAPE IN jacks.

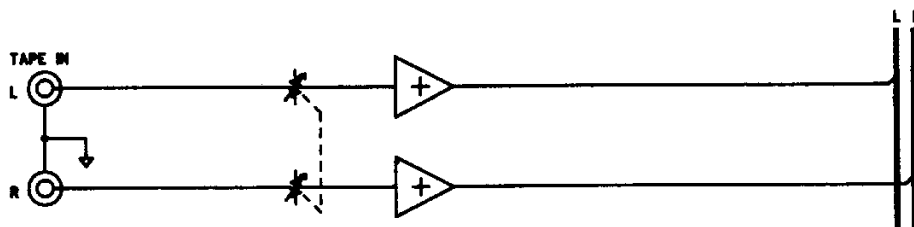

6. REC OUT CONTROL

This knob adjusts the output level of the REC OUT jacks connected to a tape deck, etc.

7. PHONES CONTROL

This knob adjusts the volume of a set of headphones connected to the headphone jack (PHONES).

8. PHONE JACK

Connect the headphones here.

You can monitor the following signals:

- The main signal output to the ST OUT jacks (Turn off all PFL and AFL switches)
- The signals input to each input channel and pressed through the 3-band EQ and the INPUT CH INSERT I/O jack (Turn on a channel PFL switch).
- The signal output to MONO OUT (Turn on the MONO OUT AFL switch).
- The AUX signals output from each AUX SEND 1-4 jack. (Turn on an AUX SEND 1-4 switches)

9. MONO OUT ON SWITCH

This switch turns the MONO OUT on/off.

10. MONO OUT AFL SWITCH

When this switch is on, the signal being output to MONO OUT can be monitored in the headphone.

11. MONO OUT FADER

This fader adjusts the output level of the MONO OUT connector.

12. METER SELECTOR SWITCH AND METER SECTION

The meters are dual function LED meter that indicate signal levels as selected by the METER SELECTOR switch.

(When METER SELECTOR is OFF)

- STEREO L,R displays the output levels of the STEREO out jacks.

(When METER SELECTOR is ON)

- PFL/AFL level displays the input level of the channel whose PFL switch is on, or the output level of the MONO OUT, or AUX SEND jack whose AFL switch.

13. PHANTOM POWER SWITCH

This switch turns the internal phantom power supply on/off. When is the "ON" position, the PHANTOM indicator will light, and 48V DC power will be provided between pin 2 and pin 3 of the XLR-type jack.

If you do not need phantom power, be sure to turn this to the "OFF" position.

14. POWER SWITCH

This switch turns the power ON/OFF. When in the "ON" position, the power indicator will light.

15. POWER INDICATOR

This indicator lights when the power switch is turned on.

16. PHANTOM INDICATOR

This indicator lights when the PHANTOM switch is turned on, indicating that phantom power is being supplied.

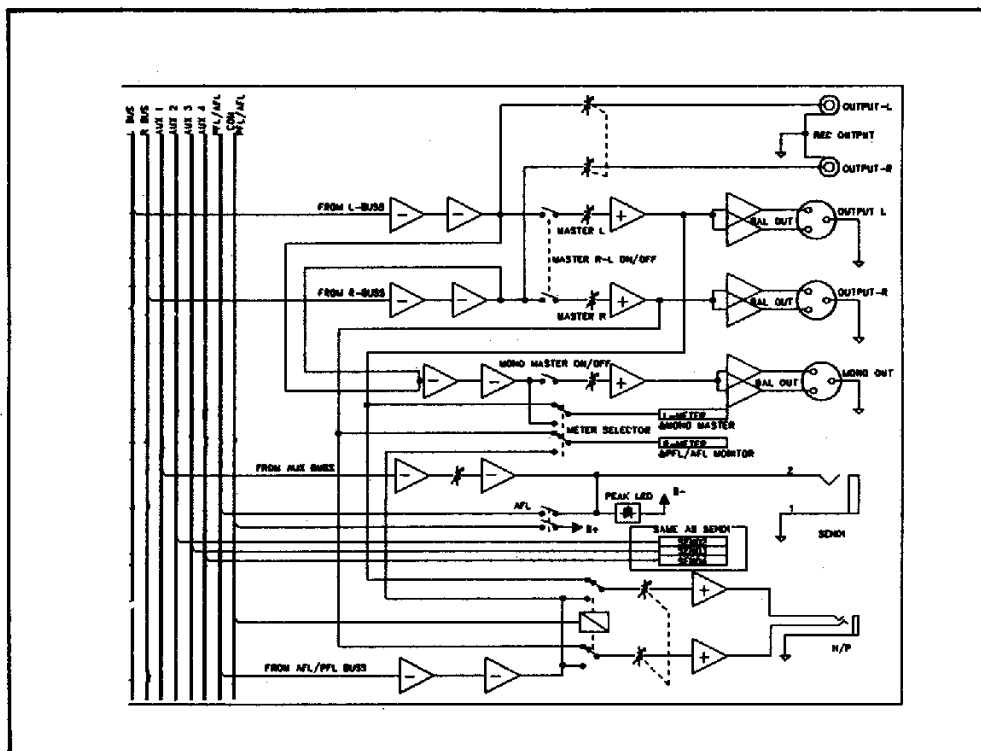

■ CONNECTORS

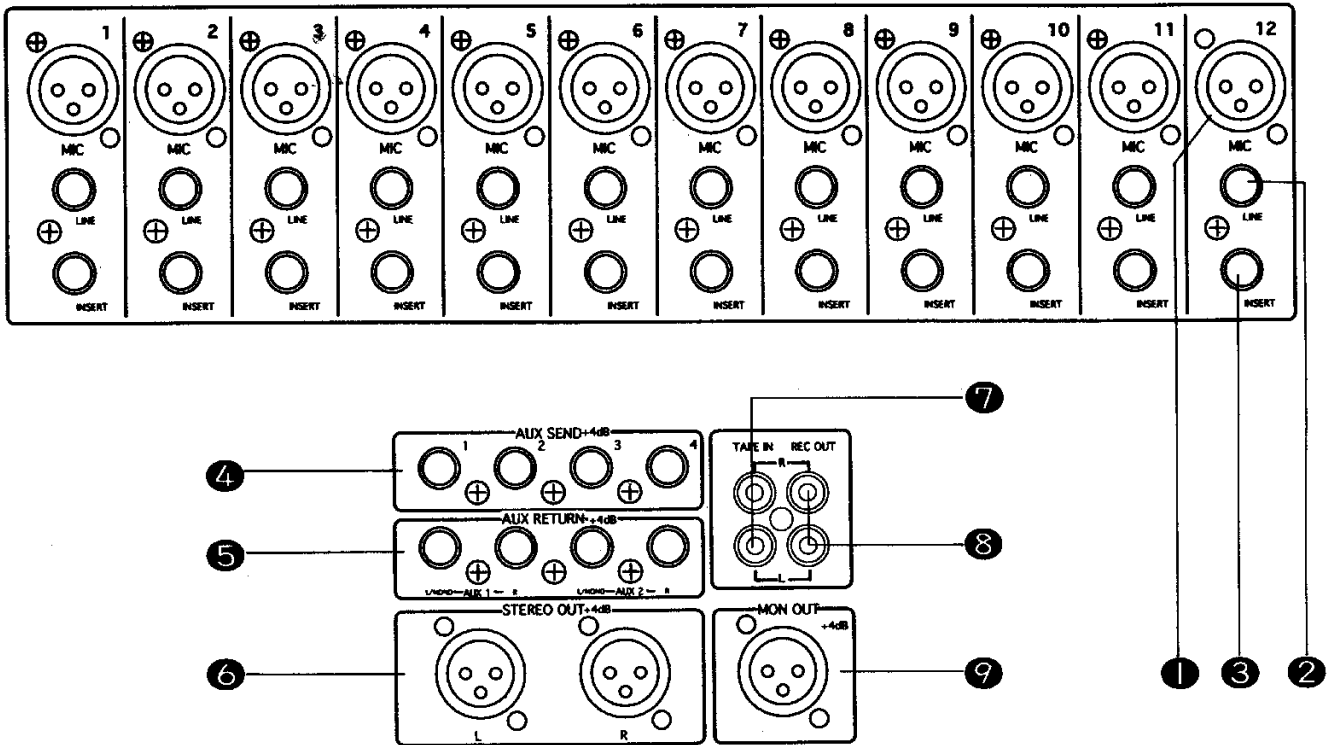

1. MIC INPUT

These are XLR-type connector. (1: sleeve, 2: hot, 3: cold)
Nominal input level is -60dB .

Phantom power ($+48\text{V}$) can be supplied to these jack. Phantom power is turned on/off using the phantom switch.

2. LINE INPUT

These are $1/4"$ phone jacks which input the signal for each input module. Nominal input level is -20dB .

(tip: hot, ring: cold, sleeve: ground)

3. INSERT I/O JACKS (0dB)

These are $1/4"$ phone jack patched in front of the input module fader. The nominal input level and impedance is $0\text{dB}/600\Omega$, and the nominal output level and impedance is $0\text{dB}/10\text{K}\Omega$. These are unbalanced TRS jacks, with tip = out, ring = in and sleeve = ground.

4. AUX SEND 1~4

These are unbalanced jacks with a nominal output and impedance of $+4\text{dB}/600\Omega$. (AUX1 and 2 are pre-fader, and AUX 3 and 4 are post-fader)

5. AUX RETURN (L/MONO, R)

These are unbalanced jacks with a nominal input level and impedance of +4dB/10K Ω . These jacks are usually used to receive the audio returned from an effect unit such a reverb or delay, but they can also be used as supplementary inputs. If a plug is inserted in L/MONO, the same signal will be sent to both the L and R buses.

6. STEREO OUT L, R

This is the stereo output of the combined audio signals. Connect these jack to the power amp that drives your main speakers.

Alternatively, you can record the output from these jacks if you wish to use the STEREO L, R faders to adjust the audio level being recorded.

7. TAPE IN

Your DAT or cassette deck can be directly connected here for convenient monitoring. Use the TAPE IN control (master section ⑤) to adjust the level.

8. REC OUT

Your DAT or cassette deck can be connected here to record the audio signal from STEREO OUT.

In this case, the final output level is adjusted by the REC OUT control (master section ⑥), and the STEREO L, R fader settings will have no affect.

9. MONO OUT

This is the MONO OUT output jack. The MONO OUT can be used for simple recordings of a live performance, for driving a sub power amp, or to check for phase cancellation. An internal jumper can be reconnected to change the location of the MONO OUT to post-ST fader. If this is done, the MONO OUT signal will be affected by the STEREO ON switch. Internal jumper wires can be changed to move the MONO OUT signal so that it is taken after the ST fader. If you would like this change to be made, consult with your dealer.

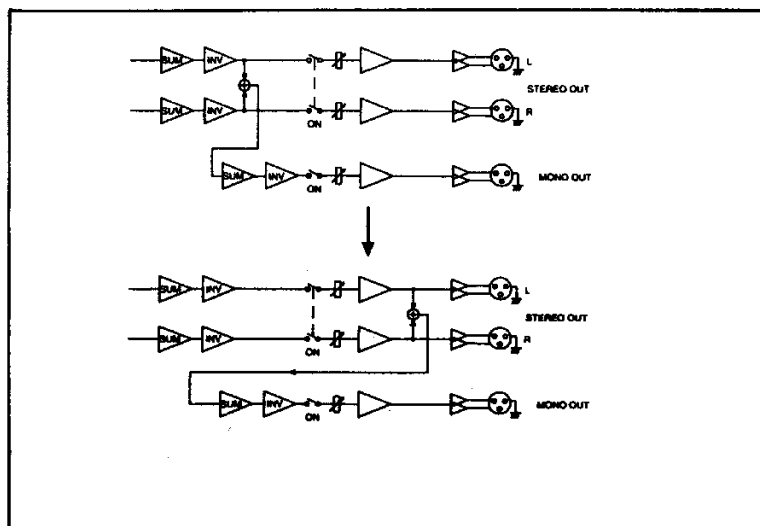

Application Example

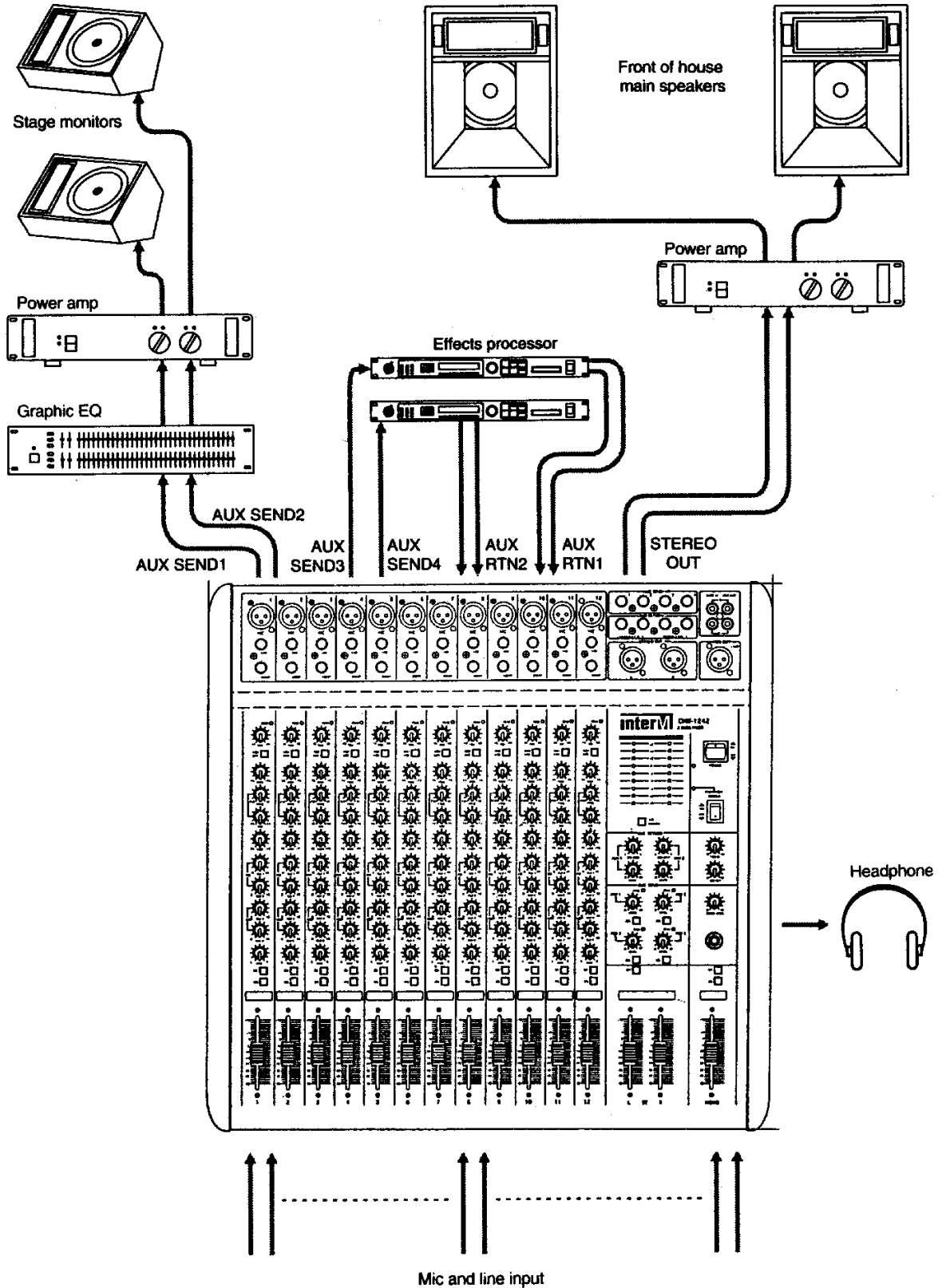

Specifications

■ General Specifications

Maximum output level	+24dB (STEREO L/R) @600Ω, 0.5% THD at 1KHz +24dB (MONO OUT) @600Ω, 0.5% THD at 1KHz +20dB (AUX SEND) @600Ω, 0.5% THD at 1KHz		
Total harmonic distortion	<0.1% @ +14dB 20Hz-20KHz (ST L/R, MONO, AUX SEND @600Ω)		
Frequency response	20Hz-20KHz +1dB, -2dB (ST L/R, MONO, AUX SEND @600Ω)		
Hum and noise (Average, $R_s = 1500$) (Measured with DIN AUDIO)	-127dB equivalent input noise		
	-95dB residual output noise (STEREO L/R, MONO)		
	-95dB residual output noise (AUX SEND 1-4)		
	-88dB (STEREO, MONO)	Master fader at nominal level, and all channel assign switches off.	
	-63dB (67dB S/N) (STEREO, MONO)	Master fader and one channel fader at nominal level.	
	-78dB (AUX SEND 1-4)	AUX SEND master fader at nominal level, and all channel assign switches off.	
	-63dB (67dB S/N) (AUX SEND 1-4)	AUX SEND master fader and one channel AUX at nominal level.	
Maximum voltage gain	84dB MIC IN to STEREO OUT 84dB MIC IN to MONO OUT 76dB MIC IN to AUX SEND 1, 2 86dB MIC IN to AUX SEND 3, 4 16dB AUX RETURN 1, 2 to STEREO OUT		
Crosstalk at 1KHz	-70dB between input channels -70dB between output channels		
Gain control (input channel)	44dB variable (-60 - -16dB)		
Input channel equalization	±15dB maximum boost or cut HIGH: 12KHz shelving MID: 250Hz - 5KHz peaking (variable) LOW: 80Hz shelving * Turnover/rolloff frequencies: located 3dB below maximum boost/cut		
LED meters	10-segment LED × 2 STEREO L/R (switchable) PFL or AFL (switchable)		
Channel peak indicators	An indicator for each channel turns on when the pre-channel fader signal is 3dB below clipping.		
Phantom power	+48V, DC		
Power supply/Power consumption US and Canadian model	CMX-842 120V AC 60Hz 25W, CMX-1642 120V AC 60Hz 36W	CMX-1242 120V AC 60Hz 31W	
General model	CMX-842 230V AC 50Hz 25W, CMX-1642 230V AC 50Hz 36W	CMX-1242 230V AC 50Hz 31W	
British model	CMX-842 240V AC 50Hz 25W, CMX-1642 240V AC 50Hz 36W	CMX-1242 240V AC 50Hz 31W	
Dimensions (W × H × D)	CMX-842 468 × 509 × 109 mm CMX-1642 632 × 509 × 109 mm	CMX-1242 520 × 509 × 109 mm	
Weight	CMX-842: 10.5kg	CMX-1242: 12kg	CMX-1642: 14kg

■ Input Specifications

Input Connector	Input Impedance	Nominal Impedance	Input Nominal Level	Connector Type
MIC	4K Ω	50~600 Ω	-60dB	XLR 3-31 Type Balanced
LINE	10K Ω	600 Ω	-20dB	Phone Jack (TRS) T = hot R = cold S = GND
AUX Return	10K Ω	600 Ω	+4dB	Unbalanced Phone Jack
Insert In	5K Ω	600 Ω	0dB	Phone Jack (TRS) T = Out R = In S = GND
TAPE IN	10K Ω	600 Ω	-10dBv	RCA Pin Jack

■ Output Specifications

Output Connector	Output Impedance	Nominal Impedance	Nominal Output	Connector Type
STEREO OUT L/R MONO OUT	150 Ω	600 Ω	+4dB	XLR - 3 - 32 Type
REC OUT	2K Ω	10K Ω	-10dBv	RCA Pin Jack
AUX SEND 1-4	75 Ω	600 Ω	+4dB	Unbalance Phone Jack
INSERT OUT	600 Ω	10K Ω	0dB	Phone Jack (TRS) T = Out R = In S = GND
Phone Out	100 Ω	40 Ω	3mW	ST Phone Jack

*0dB = 0.775 Vrms
0dBv = 1Vrms

*Specifications and appearance and subject to change without notice for product improvement.

Block and Level Diagram

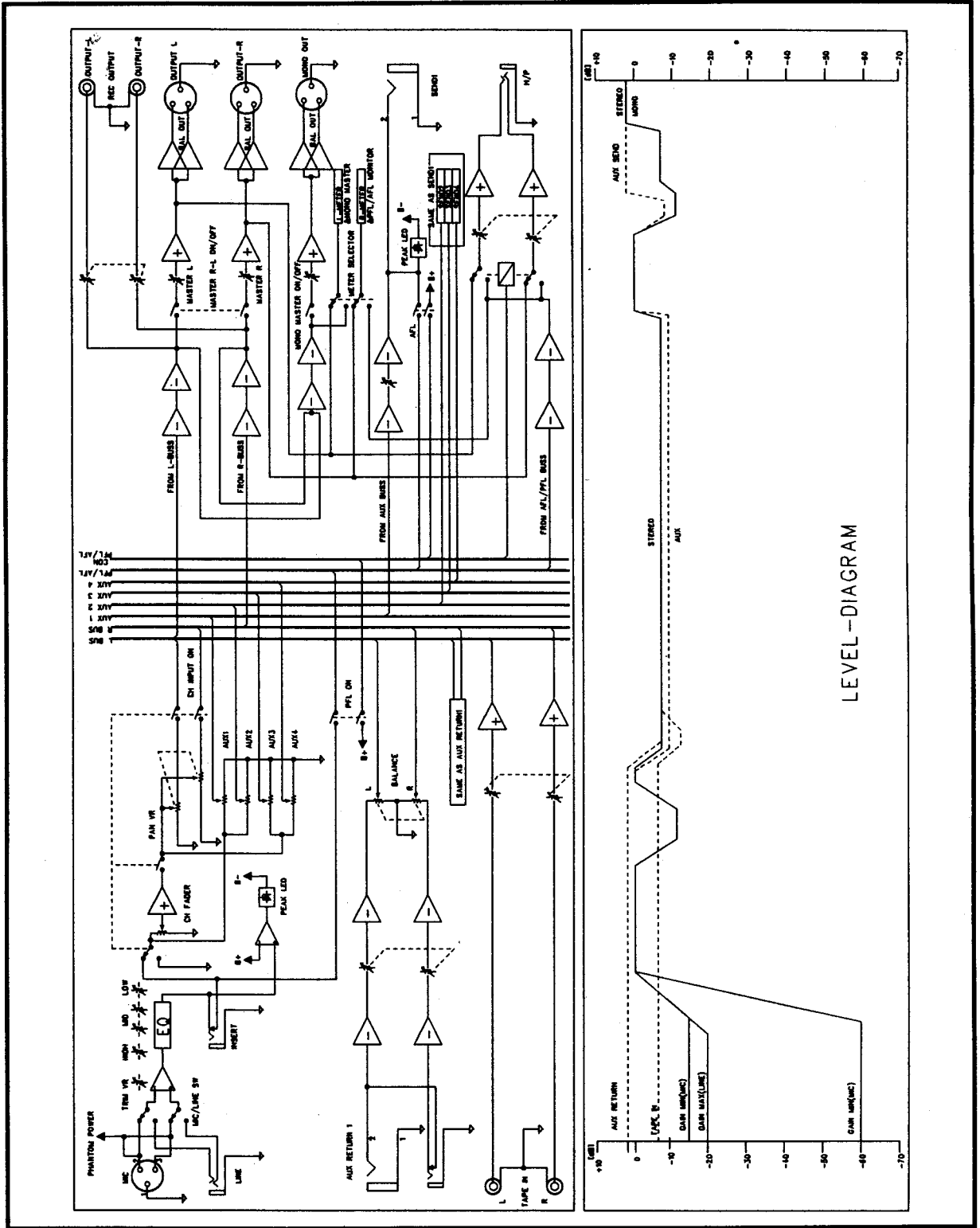

Schematic Diagram

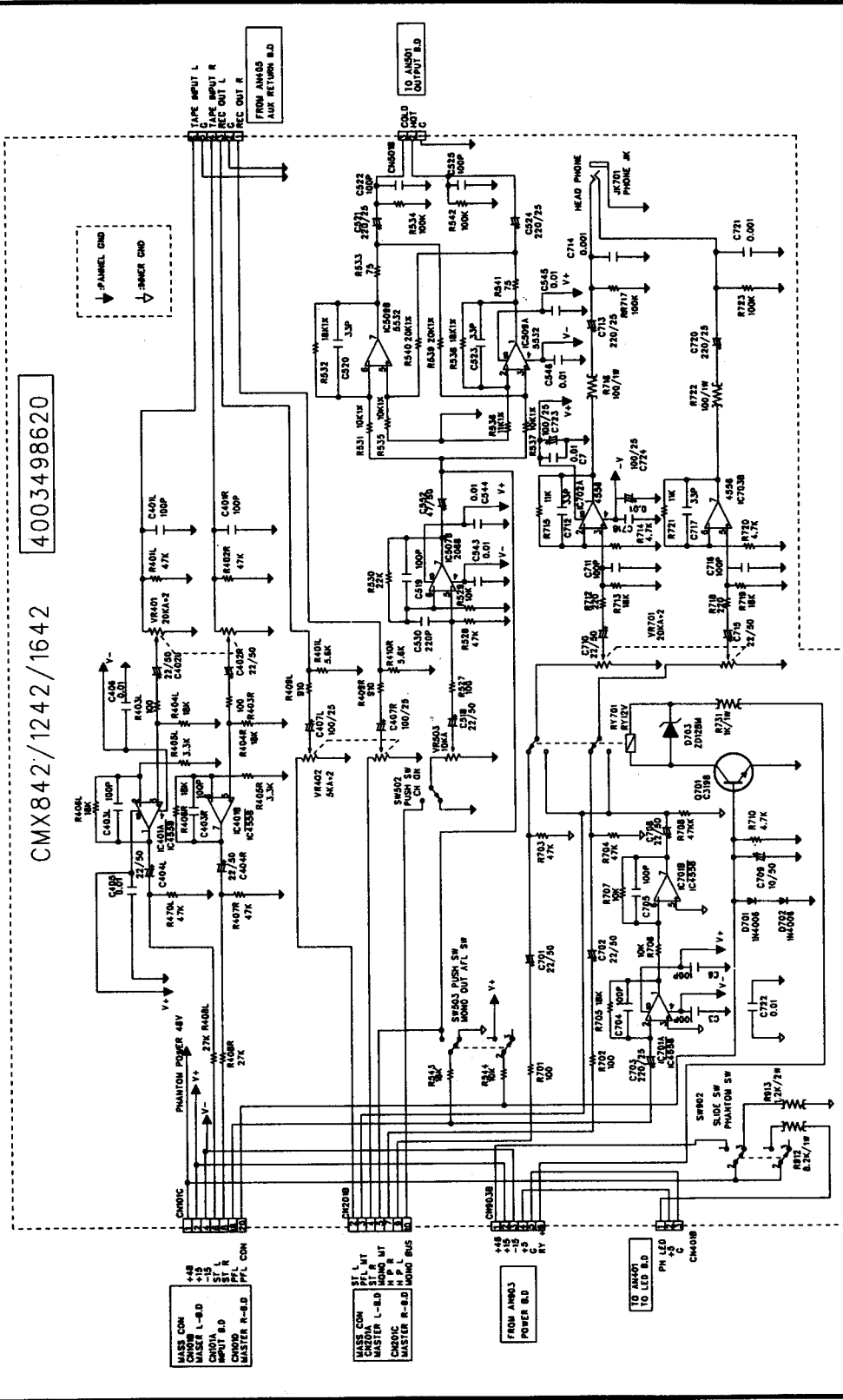

interM

MADE IN KOREA
NO : 9007927510