

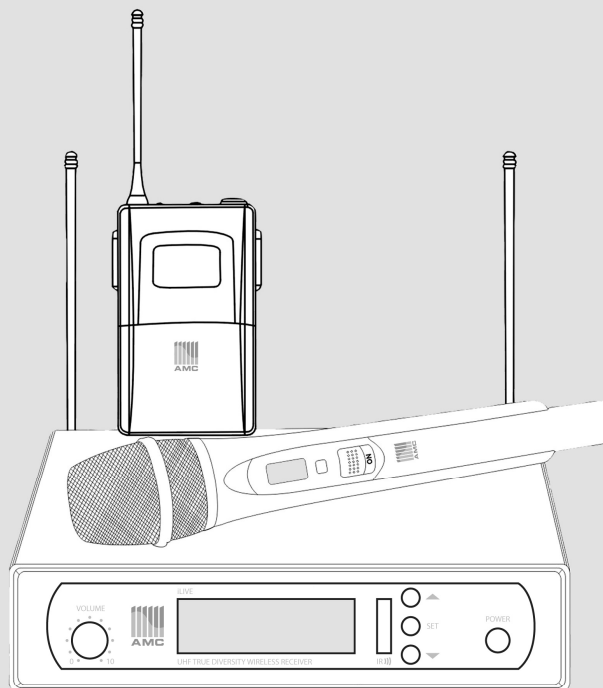

iLive

UHF WIRELESS SYSTEM



User Manual

The New iLive series of AMC Wireless systems

Created for active musician and presenters who also manage their own sound, AMC iLive improves your performance and simplifies your setup.

Innovations such as automatic frequency selection and automatic transmitter setup make wireless system management effortless. iLive wireless microphone system deliver the crystal clear sound quality that pro audio engineers trust.

CONTENTS:

Receiver features	3
Handheld Transmitter	8
Body pack Transmitter	10
Changing Batteries	11
Operation	13
Troubleshooting	15
Specifications	16

3 Receiver Features

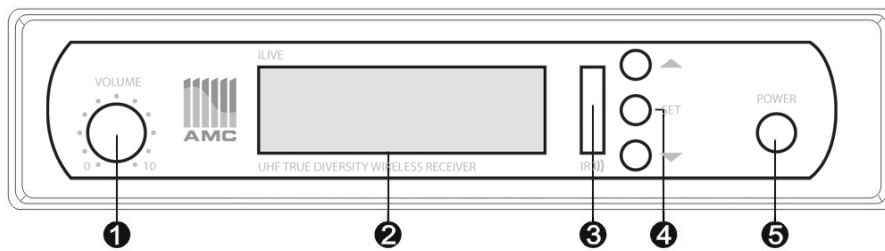

- ❶ Volume control knob
- ❷ LCD display
- ❸ IR Window for data transfer to transmitter
- ❹ Controllers: Press "SET" to enter menu, to navigate menu press "▲" or "▼", to select item press "SET". Press and hold "▲" "▼" button to select the frequency and channel.
- ❺ Power button switch: When the Power is switched on, the LCD should be lit, Press and hold the button for 3 seconds, to turn off the receiver.

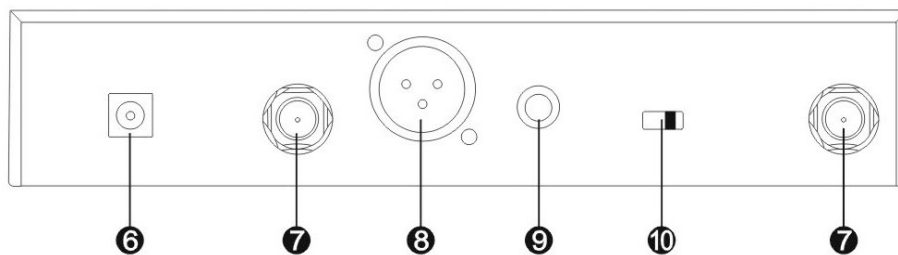

- ❻ AC power supply
- ❼ Antenna input
- ❸ XLR balanced audio output
- ❹ 1/4" unbalanced audio output
- ❺ Audio level switch

4 Receiver Features

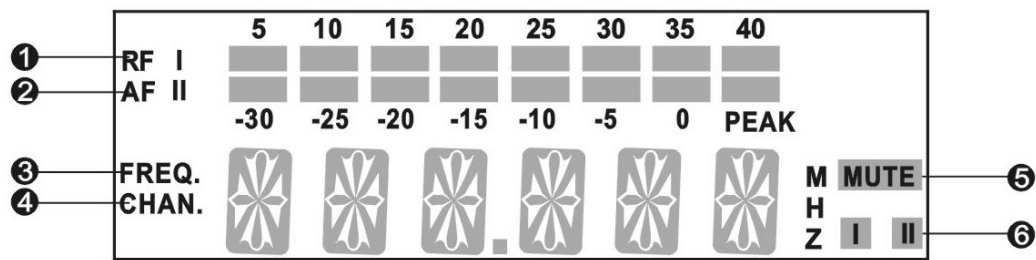

- 1 8-step level display showing incoming RF signal
- 2 8-step level display with "PEAK" warning showing incoming AF signal
- 3 Display for the "Frequency" menu. (When the FREQ light glows, displayed numbers show active frequency).
- 4 Display for the channel number (this displays active channel)
- 5 Squelch (MUTE) indicator: with the active mute, no signal is transmitted to outputs
- 6 Diversity display (shows if antenna I or antenna II is active).

Operating Menu

- Before turning on the receiver, firstly ensure that the transmitter is switched off, and then adjust receiver volume to the min.
- Check for Audio and Radio frequency decibel meters. If values are high exchange the channel to avoid the noise spot, it may also increase the static chirp value, enhancement anti jamming ability.
- Lastly turn on the transmitter power source, the corresponding channels radio frequency decibel meter lightens. Adjust receivers audio output level to suitable size, then speak to the microphone, the receiver audio frequency decibel meter lightens in correspondence to microphone volume level. If voice output is not hearable and the decibel meter is not bright, overhaul transmitter and receiver.

* Operating Receiver

(Important: with the "▲" or "▼" buttons you can directly switch between the factory-preset frequencies (Channels presets). The display starts flashing by indicating that your selection is active).

1. Automatic Transmitter setup (IR)

Press "SET" button, The LCD Display should display "PRG IR" as below. Put the receiver IR window to match the transmitter IR window, and hold for 2-3 seconds, this scans for a clear channel and sets the receiver to that channel.

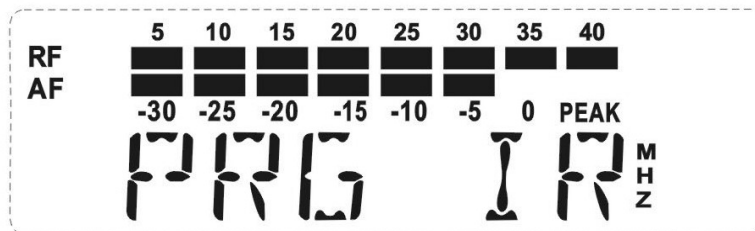

2. Display control

Press "SET" button, The LCD Display should display "DISPL" as below.

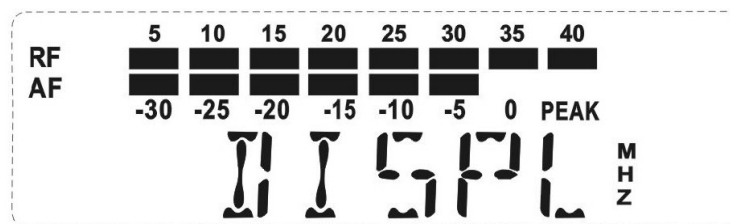

With all transmitters and receivers you can choose whether the frequency or the channel number is displayed. Select the "DISPL" menu by pressing the "SET" button until "DISPL" appears on the display, after a short pause the current setting is displayed.

With the "▲" or "▼" buttons you can now choose between:

Channel number: "CHANNEL"

Frequency: "FREQU"

Chosen mode starts flashing, pressing SET buttons returns to the menu top level.

New information is now displayed.

3. Selecting the frequency, channel number

Press SET button so that the following information is displayed:

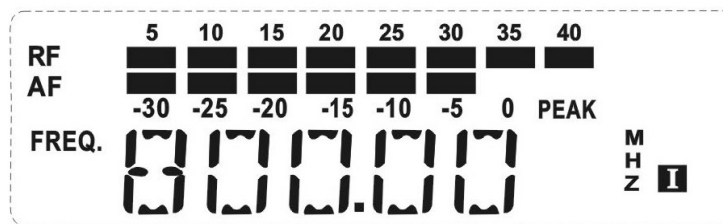
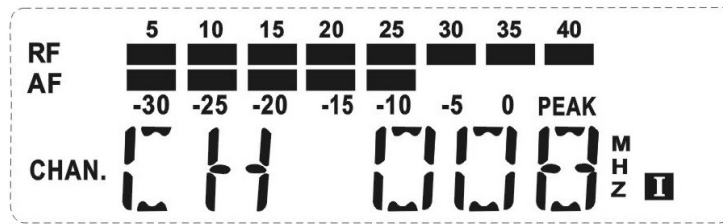

(Note: with the “▲” or “▼” buttons you can directly switch between the factory-preset frequencies (Channels presets). The display starts flashing by indicating that your selection is active).

4. Adjusting the squelch threshold (receivers only)

Press SET button display as below:

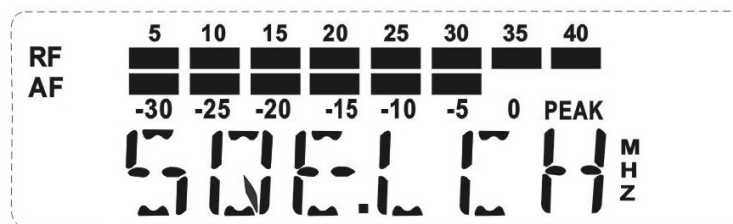

Select the "SQELCH" in menu by pressing the SET button until "SQELCH" appears on the display; after a short pause the current squelch setting is displayed. With the “▲” or “▼” you can now select a different setting. The squelch can be switched

of (0 dB) or adjusted in 5 db steps. Selecting a smaller value reduces the squelch threshold, selecting a higher value increases the squelch threshold. New setting starts flashing on the display. Set the squelch threshold to the lowest possible value that suppressed hissing noise while the transmitter is switched off. If the squelch threshold is set too high, the transmission range will be reduced. Factory preset set to -15dB.

5. Locking and Unlocking Controls

Press SET button until you will see the LCD display as below

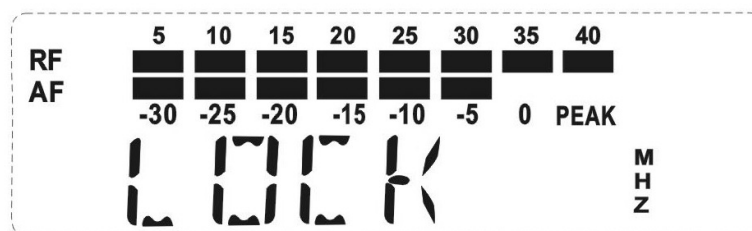

You can lock the “▲ ▼” buttons to prevent accidental programming or switching off during operating.

Activating the Lock-mode function

Select “LOCK” in menu by pressing the “SET” button. Current setting is indicated on the display. Press “▲” button to activate the lock-mode function. “LOCK ON” starts flashing on the display. Press “SET” button to return to the top menu level.

Note:

If you press “▲” / “▼” buttons, “LOCK” appears on the display informing that the buttons are now locked.

Deactivating lock-mode function

Select “LOCK” in menu by pressing “SET” button. “LOCK ON” appears on the display.

Press “•” button to deactivate the lock-mode function. “LOCK OFF” begins to flash on the display. Press “SET” button to return to the top menu level. The display switches back to the standard mode and the buttons can now be operated normally.

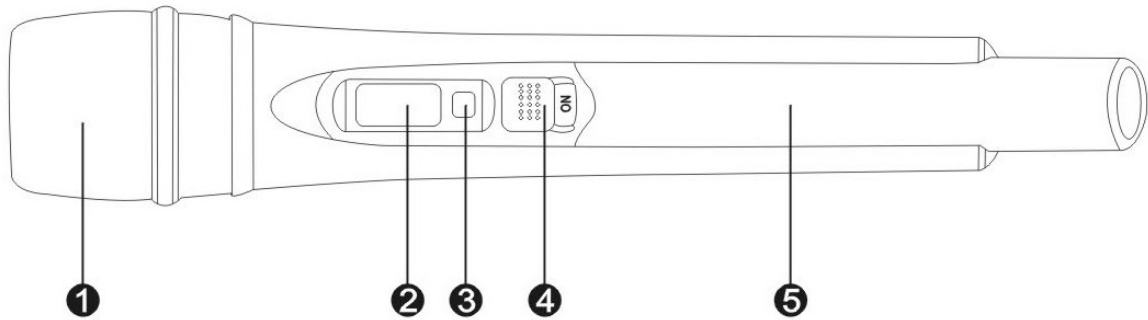

- ❶ Sound inlet basket
- ❷ Display section
- ❸ IR port
Receives infrared beam to synchronize frequencies
- ❹ Power on/mute/off
- ❺ Microphone body

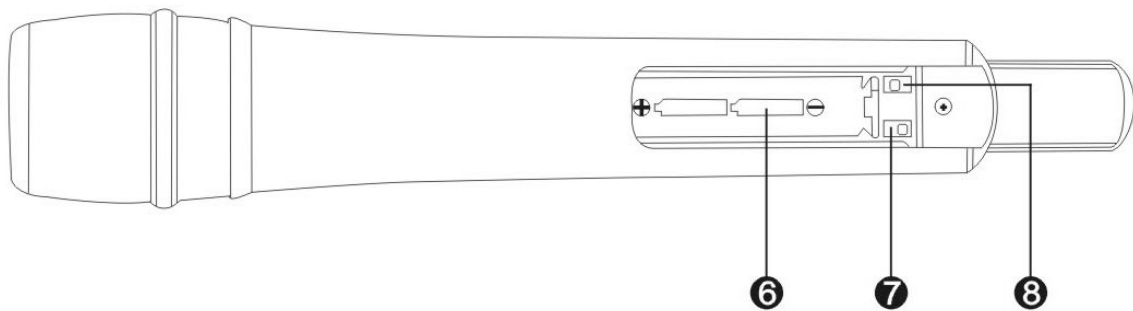

- ❻ Battery port: 2*5 AA Alkaline batteries
- ❼ RF LOW and HIGH switch
- ❽ LOCK switch

* Hand-held transmitter

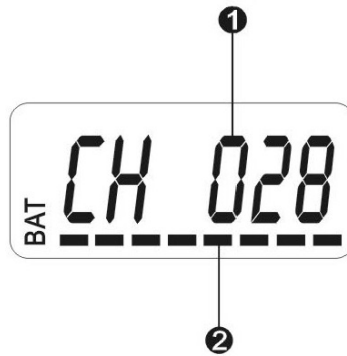

- ❶ 3 digit display showing the channel number
- ❷ 8-step level display showing battery level

* Operating Hand-held Transmitter

After switching transmitter's power on, LCD displays the CHANNEL and a BATTERY LEVEL. If you want to change the active channel, you need change the channel from the receiver first and then, put the transmitter IR port to the receiver IR port, and Press SET button to synchronize frequencies. When channel setting is finished switch on the lock in the battery part to lock the receivers channel.

* Body Pack Transmitter

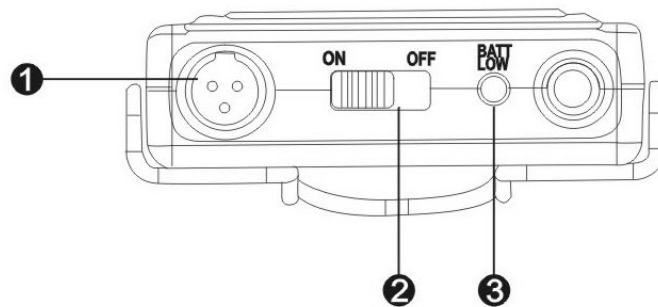

- ❶ 4-Pin Microphone Input Jack
- ❷ On-Off switch
- ❸ Indicator level: When the power is switched "ON" indicator flashes, indicating that the battery capacity is normal. When indicator shows no activity unit does not have power, or the battery was not loaded properly. If the battery indicator lamp is shining, it shows that the battery is low and needs to be replaced.

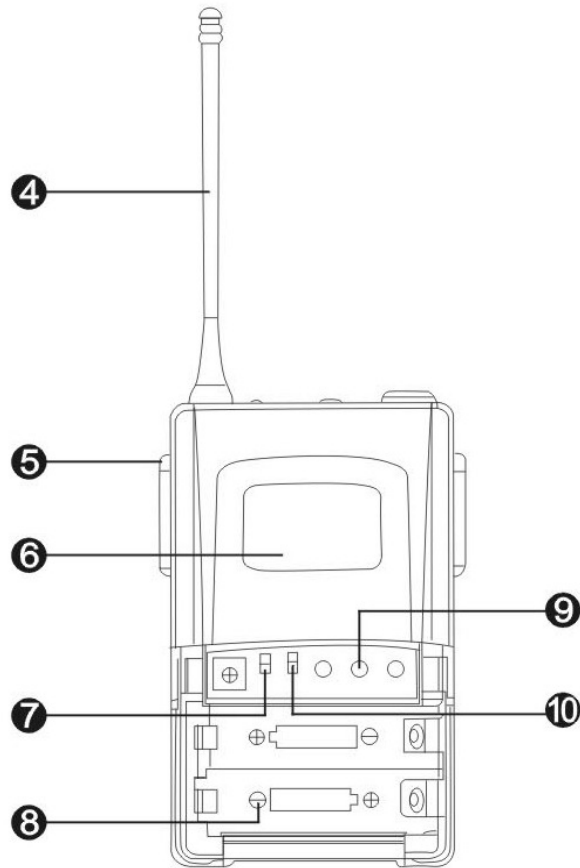

- ④ Transmitting antenna: 1/4 wave length flagellated transmitting antenna
- ⑤ 180 degree rotating belt clip
- ⑥ LCD Display: Displays current active channel and battery status
- ⑦ Infrared (IR) indicator
- ⑧ Battery compartment: Installs 2 AA Alkaline battery
- ⑨ Control push-button: SET, "▲" / "▼"
- ⑩ High and low RF power transformation key

* Body Pack Transmitter operation

The operating procedure is the same as the handheld transmitter. Body pack transmitter also features height power conversion, volume control function. It also adapts different sound and other exterior sound sources.

11 Changing Batteries

* Handheld Transmitter

1. Open the battery cover

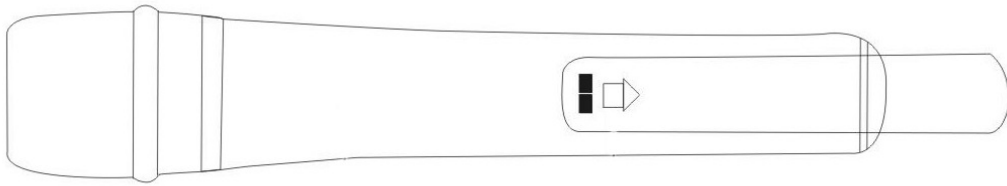

2. Insert the 2*AA Alkaline battery

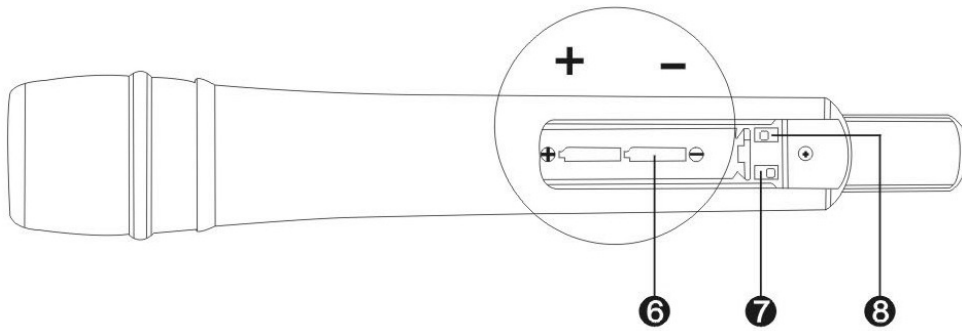

3. Close the battery cover

12 Changing Batteries

* Body Pack Transmitter

1. Open the battery cover

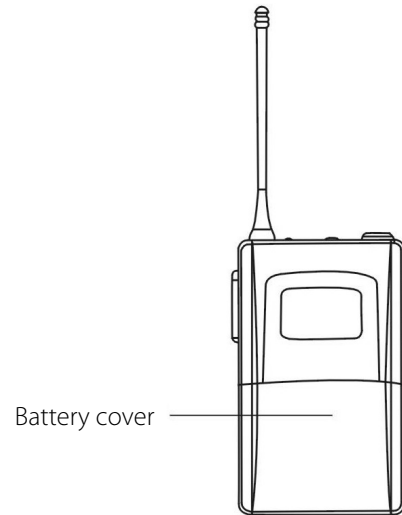

2. Insert the 2*AA Alkaline battery

3. Close the battery cover

- When selected frequency in the 25MHz band width allocation is without inter-modulations, 4-8 transmitters may be used simultaneously, if more wireless microphones is needed, other frequency hand type equipment has to be used.
- Distance between the receiver and the transmitter should not be too far, minimum distance is 1 meter.
- If the receiver's RF condition is not ideal, external high gain antenna, even the antenna amplifier, may achieve very obvious gain effects.
- The receiver and the transmitter must use the same frequency.
- When using multiple receivers it is suggested to install the high gain antenna, antenna amplifier and the receiver shunt.
- Both, transmitter and receiver should be in direct access and least obstacles should be met in path between them.
- When the receiver is used with omni-directional antenna, the antenna should be minimum 0.5m from the wall, and should be kept far away from any other metal constructions.
- When the multiple transmitter's are used together, they should be separated by at least 20cm, in order to avoid disturbs.
- After finished using the transmitter, switch off the power source. Remove the batteries when storing for long time.

- Handheld transmitter should be grasped in the middle of full length. Not too close to the microphones head so microphone's electrical pickup effect would not be affected. Not too close to base antenna position so emission efficiency would not be cut, and service range would not be reduced.
- Changing active distance between the microphone and lips may cause fluctuation in high frequency reproduction.
- Belt type transmitter uses 1/4 wave length whip antenna, this antenna should not contact with the human body, also should be separated from microphones cable which would reduce the overall efficiency.
- Adjusts between the microphone and mouth's distance, may fluctuate the high bass.
- When storing switch of receiver's power and remove batteries from transmitters.

Problem	Solution
Receiver does not show any operation signs	Make sure AC adapter is securely plugged into electrical outlet and in to DC input connector on rear panel of receiver
Distortion or unwanted noise	<p>Remove nearby sources which may interfere with radio frequency transmission (CD players, computers, digital effects, in-ear monitor systems, etc.)</p> <p>Change receiver and transmitter to a different frequency</p> <p>Reduce transmitter gain</p> <p>Replace transmitter batteries</p> <p>If using multiple systems, change one of active systems frequency.</p>
No RF signal	Transmission frequency should be the same as the receiving frequency, or make sure the transmitter is not out of range.
RF signal available but no audio signal	Check connector to the microphone and make sure receiver's squelch threshold is adjusted to low
Transmitter could not be turned on	Replace transmitter batteries

Specifications for system:

Carrier frequency range : 620-950MHz

Modulation : FM

Adjustable range : 25MHz

Channels : 100

Channel spacing : 250KHz

Frequency stability : $\pm 0.005\%$

Dynamic range : 100dB

Max. Deviation : $\pm 45\text{KHz}$

Frequency response : 80Hz-18KHz ($\pm 3\text{dB}$)

S/N ratio : $> 105\text{dB}$

T.H.D : $\leq 0.5\%$

Working range : 100m (Note: actual range depends on RF signal absorption, reflection, and interference)

Operating temperature range : $-10^\circ\text{C} \text{--} +40^\circ\text{C}$

Receiver :

Receiver way : Two frequency conversion super-heterodynes

Intermediate frequency : 110MHz, 10.7MHz

Antenna : BNC/50 Ω

Sensitivity : 12 dB μV (80dBs/N)

Sensitivity range : 12-32 dB μV

Image rejection : $\geq 75\text{dB}$

Max. Audio output : +10 dB V

Transmitter :

Antenna : built-in spiral antenna for the handle microphone
1/4 Wave length spiral antenna for the body pack

Power output : High 30mW ; low 3mW

Image rejection : -60dB

Battery : 2*5'AA Alkaline battery

Battery life : 30mW for 10 hours, 3mW for 15 hours